

46: Rear drive axle, AW50/51 AWD

V70 XC (01-) / XC70 (-07), 2001, B5244T3, AW50/51

AWD, L.H.D, YV1SZ58D811036138, 036138

10/12/2012



PRINT

46: Rear drive axle, AW50/51 AWD

**Final drive,
replacing**

Special tools:

998 5972

999 5743

Note! As the illustrations in this service information are used for different model years and / or models, some variation may occur. However, the essential information is always correct.

Preparations

Note! Check that the parking brake is not applied and that the gear selector is in position P.

Removing the rear wheels and the drive shaft screw

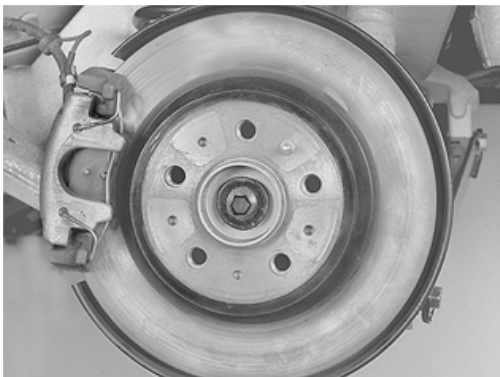

Remove:

- the rear wheels
- the screw for the drive shaft and wheel hub on both sides.

Removing the rear section of the exhaust system

Raise the car.
Support the front section of the exhaust system so that there is no strain on the exhaust manifold.

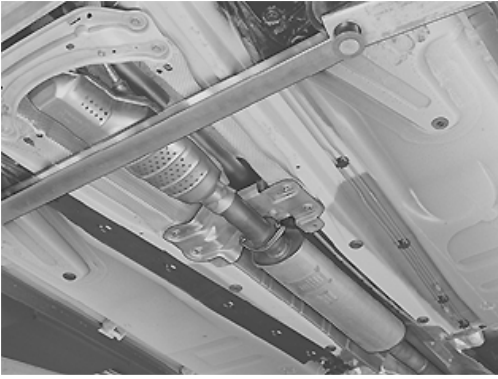

Remove:

- the rear exhaust system assembly
- the exhaust system from the mountings in the rear axle member.

Removing the propeller shaft



Mark the position of the joint on the flange.

Remove the screws from the joint. Use counterhold 999 5743 .

Leave one screw in place by a few threads for safety.



Remove the screws from the support for the propeller shaft center bearing.

Slacken off the screws in the support for the center bearing on the right-hand side a few turns. Fully remove the screws on the left-hand side

Let the member hang down so that the propeller shaft can be angled.

Remove the screw from the joint.

Press the shaft joints together.

Remove the shaft from the carrier plate. Move the shaft to one side.

Tie up the shaft.

Removing shock absorbers, torque rods and anti-roll bar links (both sides)

Remove:

- the shock absorber from the trailing arm
- the screw for the torque rod mounting in the wheel bearing housing
- the anti-roll bar link from the

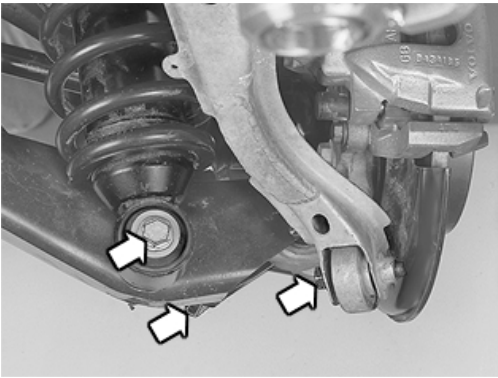

anti-roll bar.

Removing track rods and trailing arms (both sides)

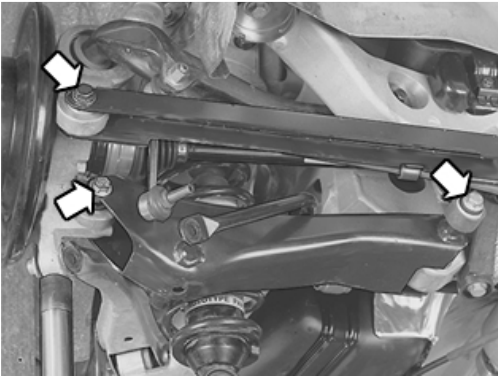

Press the wheel bearing housing upwards so that the tie rod is horizontal.

Unhook the mechanical cable from the clip.

Remove:

- the screw for the tie rod in the wheel bearing housing. Unhook the tie rod from the wheel bearing housing. Lift up the tie rod further so that the screw in the trailing arm is exposed
- the screws for the trailing arm. First press the trailing arm outwards. Move it downwards at the inner mounting. Remove the trailing arm.

Removing the anti-roll bar

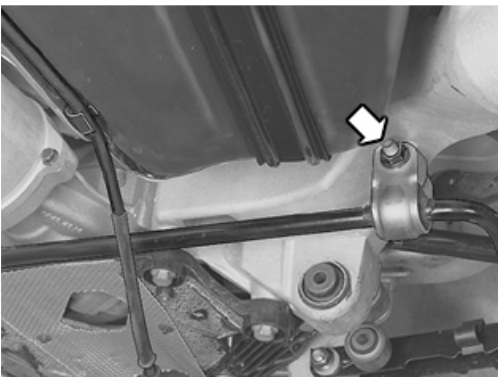

Remove the cables for the parking brake from their mountings in the lower cover and in the heat deflector plate.

Carefully bend out the mechanical cables towards the wheel bearing housing. Ensure that the cables do not crack or break.

Remove:

- the screws for the mountings for the anti-roll bar in the rear axle member
- the anti-roll bar.

Removing the final drive housing from

the rear axle member

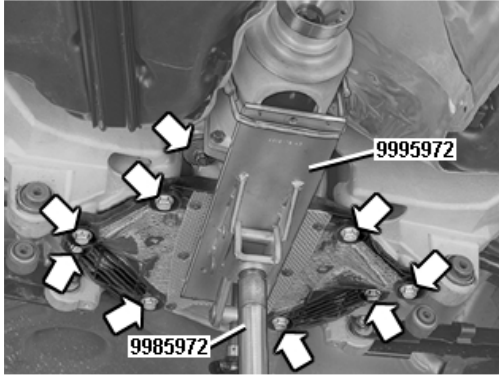

Position mobile jack 998 5972 together with fixture 999 5972 . Adjust the plate against the lower cover and final drive. Install a large hose clamp above the pipe and plate.

Remove:

- the front screw for the final drive housing
- the 8 screws for the cover/rear axle member.

Lowering the final drive housing

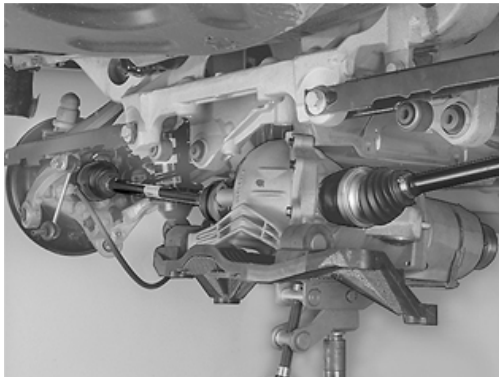

Lower the final drive together with the drive shafts so that the center of the drive shaft is slightly below the center of the wheel bearing housings.

Pry out the wheel bearing housing. Remove the drive shaft from the hub.

Note! Be very careful with the drive shaft when removing it from the hub. The inner joint may be damaged if the shaft releases under its own weight.

When replacing the final drive housing, see Final drive, transferring components .

Installation

Note! For tightening torques, see Tightening torque .

Note! To ensure that there is no exhaust leakage, see Flanged joint, assembling .

Preparations for the installation of the final drive

Lift the final drive together with the drive shafts so that the center of the drive shaft is slightly below the center of the wheel bearing

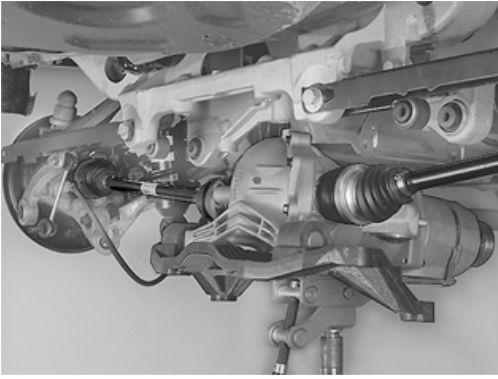

housings.
 Apply rust-proofing agent to the ends of the drive shafts.
 Press out **one** of the wheel bearing housings. Align the drive shaft in the hub.
 Then align the other side.

Installing the final drive

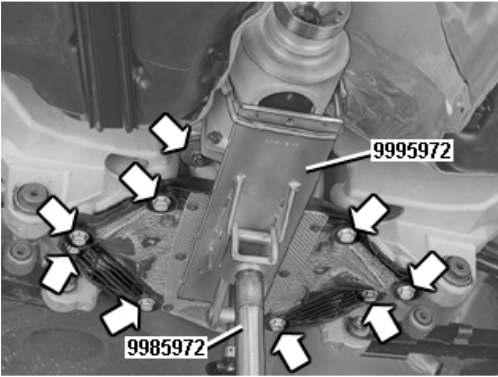

Press the final drive up against the rear axle member. Align all screws. Tighten the screws alternately. See Tightening torque: Summary of tightening torques for specific components .
 Remove the jack.

Installing the anti-roll bar on the rear axle member (both sides)

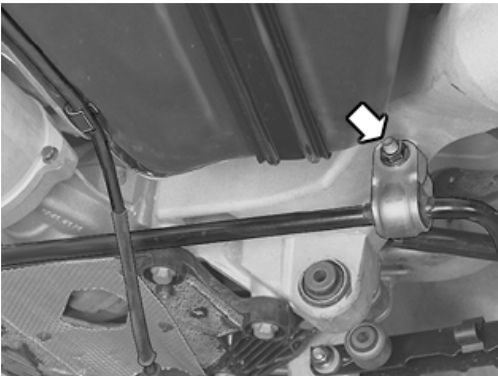

Install new lock nuts, M12. Tighten.

Note! Ensure that the cable for the parking brake passes above the ends of the anti-roll bar. Press the cables into place in the clamps on the heat deflector plate.

Installing trailing arms and track rods (both sides)

Raise the wheel bearing housing so that the hole for the trailing arm in the bearing housing and rear axle member is horizontal.
 Install the trailing arm. Use new screws, M12. Tighten.

Install the tie rod on the wheel

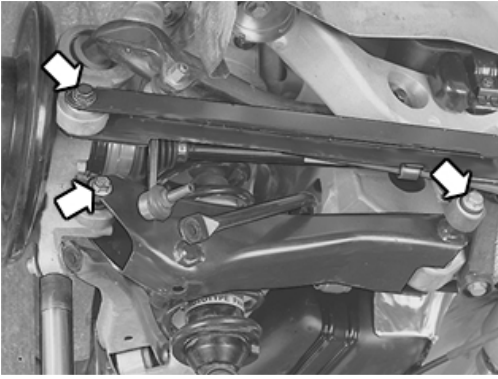

bearing housing. Use new lock nuts, M12. Tighten. Install the parking brake cable in the holder on the tie rod and in the cable mountings in the lower cover. Tighten. See Tightening torque: Summary of tightening torques for specific components .

Installing shock absorbers, torque rods and anti-roll bar links (both sides)

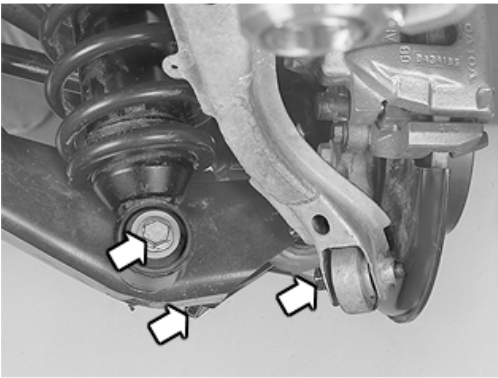

Press the trailing arm downwards when the shock absorber is being installed. Use a crow bar.

Install:

- the shock absorbers on the trailing arms. Do not tighten the screw
- the screw for the tie rod/wheel bearing housing. Do not tighten the screw
- the link to the anti-roll bar on both sides. Use a new M12 nut. Tighten.

Installing the propeller shaft

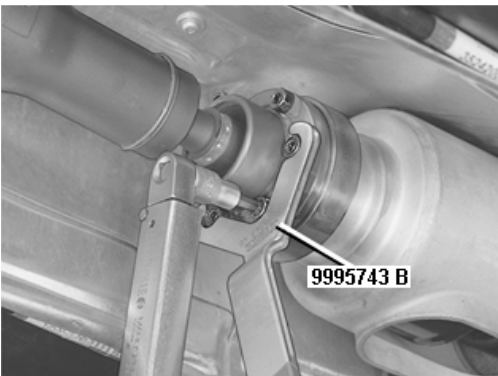

Install the propeller shaft using the marking made earlier. See Final drive, replacing: Removing the propeller shaft .

Check carefully that the mating surfaces on the propeller shaft and flange are clean.

Use new screws when installing the propeller shaft. First tighten the screws that are opposite each other. See Tightening torque: Summary of tightening torques for specific components . Then tighten all screws crosswise. See Tightening torque: Summary of tightening torques for specific components . Use counterhold 999 5743 .

Install:

- the support for the center bearing on the car body.
Tighten
- the screws for the center bearing on the propeller shaft.
Tighten.

Installing the rear section of the exhaust system



Install the exhaust system on the mountings in the rear axle member and on the front exhaust pipe/three-way catalytic converter (TWC).

Filling and checking the oil in the final drive

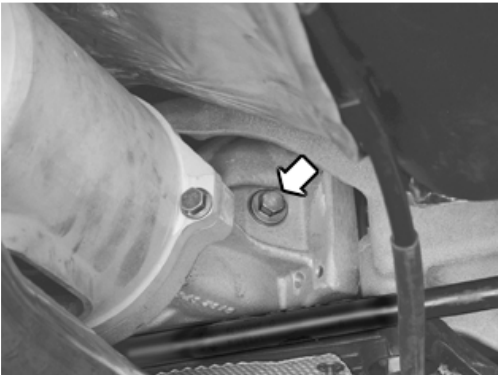

Fill the final drive with oil. P/N 116 1620-8 (1 liter container)
Volume approximately 0.7 liters.

Installing the rear wheels. Tightening shock absorbers and torque rods

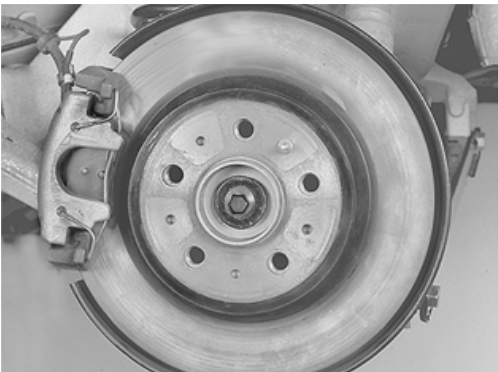

Install:

- the screws for the drive shafts on both sides. Use new screws
- the rear wheels. See Installing wheels .

Position the car on a wheel track hoist.

Tighten the M12 screws for the shock absorbers and torque rods on both sides.

Note! Check and adjust the rear wheel alignment if necessary. See Wheel alignment, checking / adjusting .

10/12/2012

PRINT