

## Spring/shock absorber rear, replacing

Special tools: [951 2911](#) , [951 2912](#) , [951 2913](#) , [999 5500](#)

**Note!** The illustrations in this service information are used for different model years and/or models. Some variation may occur. However, the essential information in the illustrations is always correct.

### Preparatory work

#### Removing components

##### Only V70

- Remove the front floor hatch from the cargo compartment
- Angle up the insulation panel
- Remove the screw and washer
- Raise the vehicle.

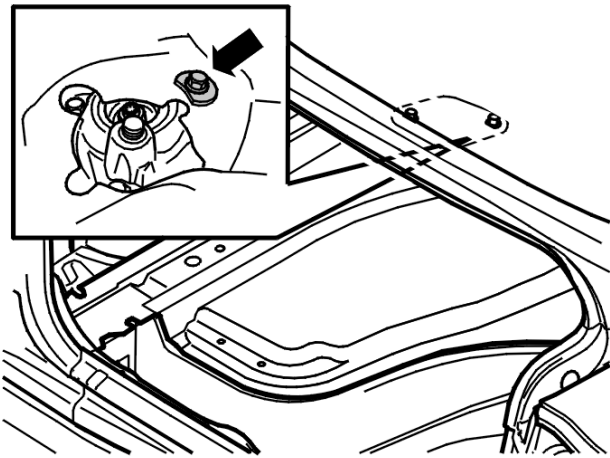
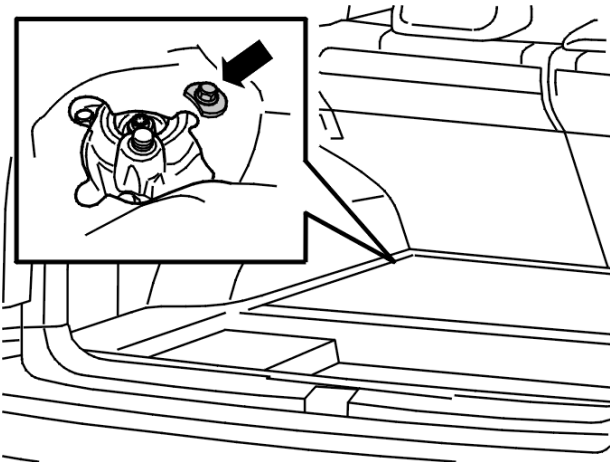

##### Only S60/S80

- Fold the rear seat forward
- Remove the clip for the rear side panel
- Push the rear side panel to one side
- Angle up the insulation panel
- Remove the screw and washer
- Raise the vehicle.

### Removal

#### Removing the mud guard

##### Remove:

- the wheel
- the mudguard on the lateral link
- the mudguard under the control arm.

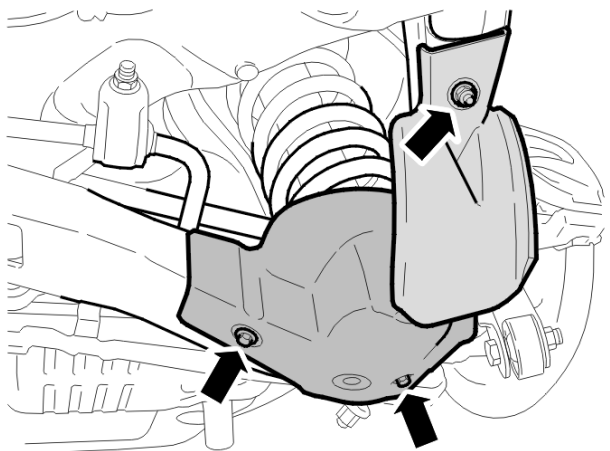

### Removing the shock absorber

**Note!** The shock absorbers are slightly compressed. Secure the control arms down. Use retaining straps.

#### Remove:

- the 2 screws for the shock absorbers on both sides
- the shock absorbers from both the control arms.

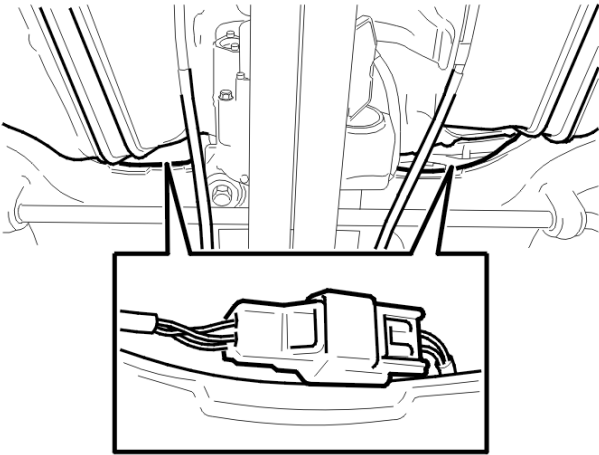
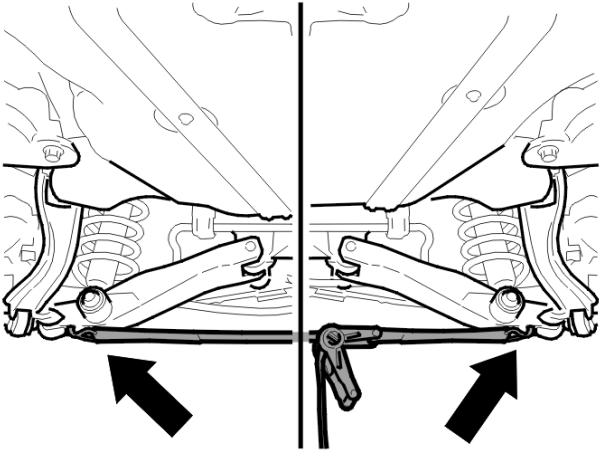

For vehicles equipped with Four-C.

Disconnect the connectors on top of the sub-frame. (Pull the connector off the rail on the sub-frame and out to the side.)

Pull up and open the connector.

Disconnect the cable harness from the sub-frame for the shock absorbers.

#### Remove:

- the 2 screws from the spring seat
- the spring strut.

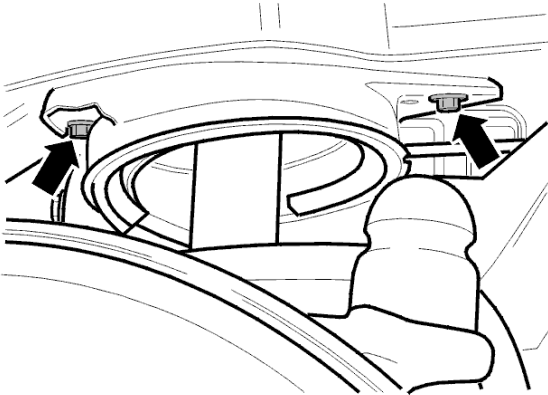

### Disassembling the spring strut

Mark the rubber shim (1) and the spring seat (2). Use a chalk mark (3) to facilitate installation.

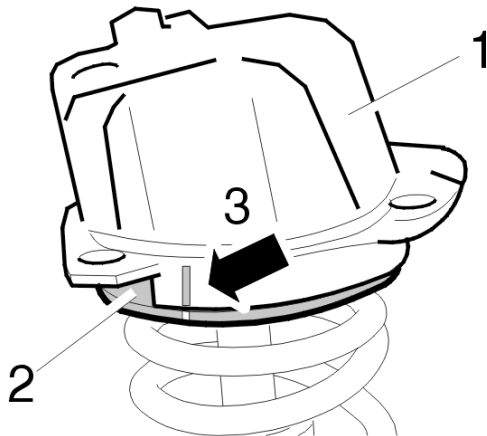

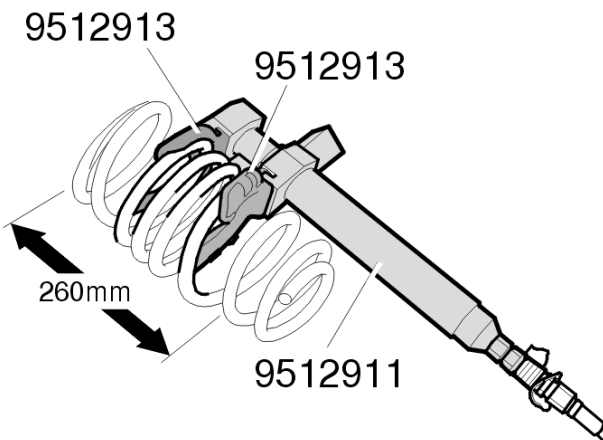
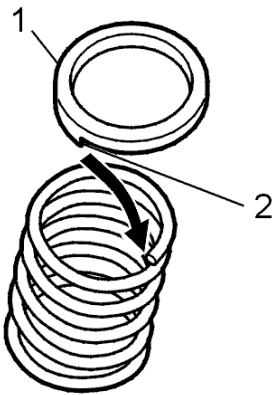
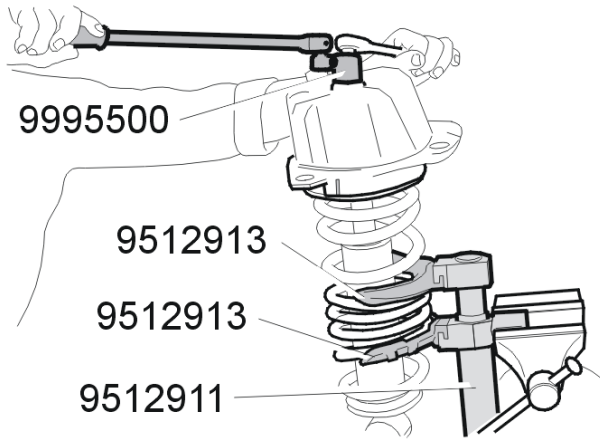

## Removing the spring

Fasten the hydraulic tool in a vise. Take the load off the springs. Use the hydraulic tool: [951 2911](#) together with claw: [951 2913](#).

Remove the nut from the spring strut mounting. Use socket: [999 5500](#) and Torx wrench TX40 as a counterhold.

### Remove:

- the spring seat
- the shock absorber.

Remove the rubber shim (1) for the spring. Position the rubber shim on the new spring. Replace the rubber liner if it is damaged.

**Note! The notch (2) in the rubber shim.**

## Only replacing the spring

Compress the new spring to a length of approximately 260 mm. Use hydraulic tool: [951 2911](#) together with claws: [951 2913](#).

## Installation

### Installing the spring

**Note! For tightening torques, see: [Tightening torque](#).**

### Install:

- install the shock absorber in the spring
- ensure that the end of the spring (1) is correctly seated (2) on the shock absorber.

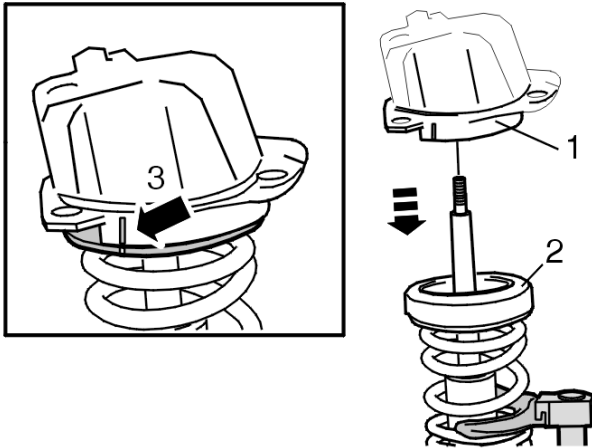
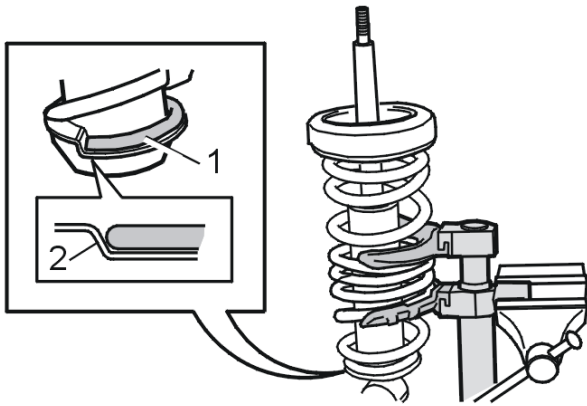

- Reinstall the spring seat (1) on the rubber shim for the spring (2). Check that the mark (3) on the spring seat is in line with the mark (3) on the rubber shim.

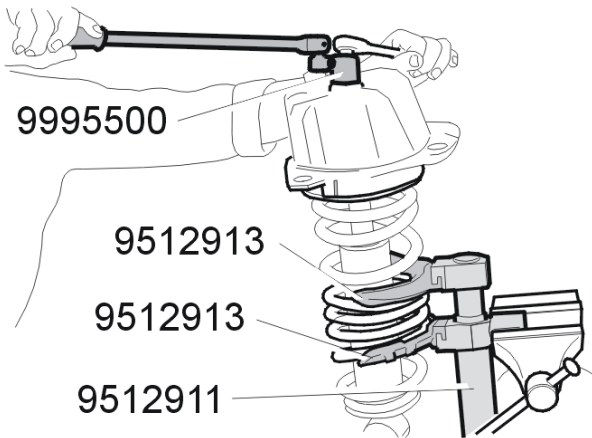

- Install a new nut on the shock absorber mounting. Use socket: **999 5500** and Torx wrench TX40 as a counterhold. Tighten. See: **Tightening torque**
- Remove the spring strut from the hydraulic tool.

### Installing the spring strut

#### Install:

- the spring strut
- the 2 x M10 screws for the spring seat.

**Note! The lower end of the spring must be turned in towards the center of the car. This applies to both sides.**

For vehicles equipped with Four-C  
Install the cable harness for the shock absorbers on the sub-frame.

The connector on top of the sub-frame.

### Installing the shock absorber

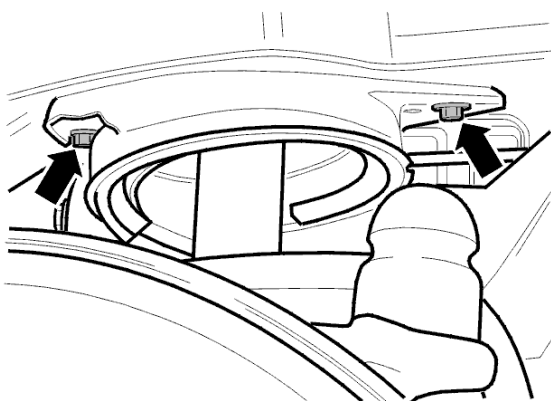

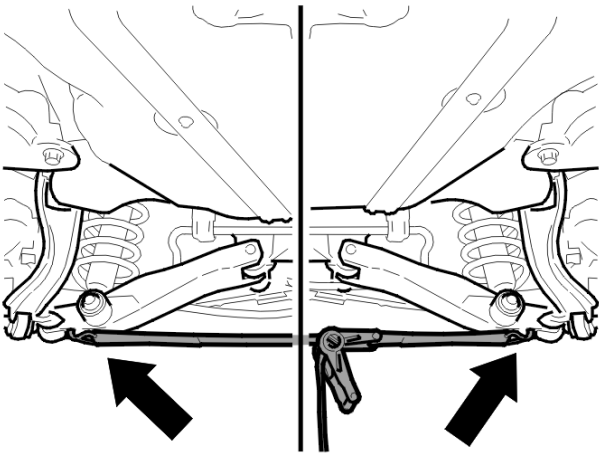
**Install:**

- the shock absorbers on the control arms, M12
- the screw for the shock absorber.

Remove the tensioner strap.

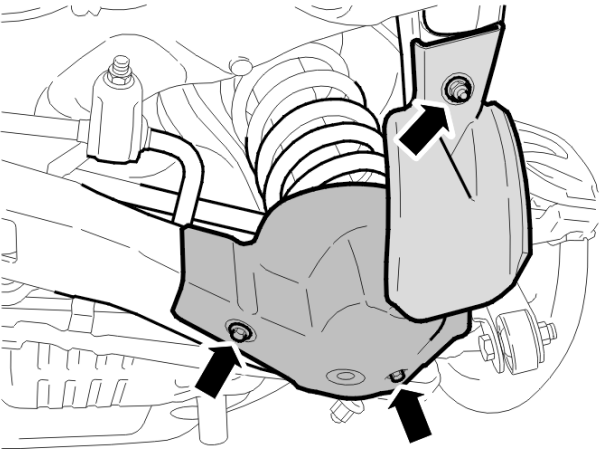
**Installing the mudguards****Install:**

- the mudguard on the lateral link, 1 x M8
- the mudguard under the control arm using the 2 screws
- the wheel. See: [Installing wheels](#) .

Lower the vehicle.

**Finishing****Only V70****Install:**

- screw and washer, 1 x M8
- fold the insulation back into place
- the front floor hatch.

**Only S60/S80****Install:**

- screw and washer, 1 x M8
- fold the insulation back into place
- fold back the rear side panel
- the clip to the rear side panel
- fold the rear seat back into place.

Check and adjust the headlamps in accordance with:

[Headlamps, aligning](#) .